

RF/BB Connections v. 0.0 ed.7

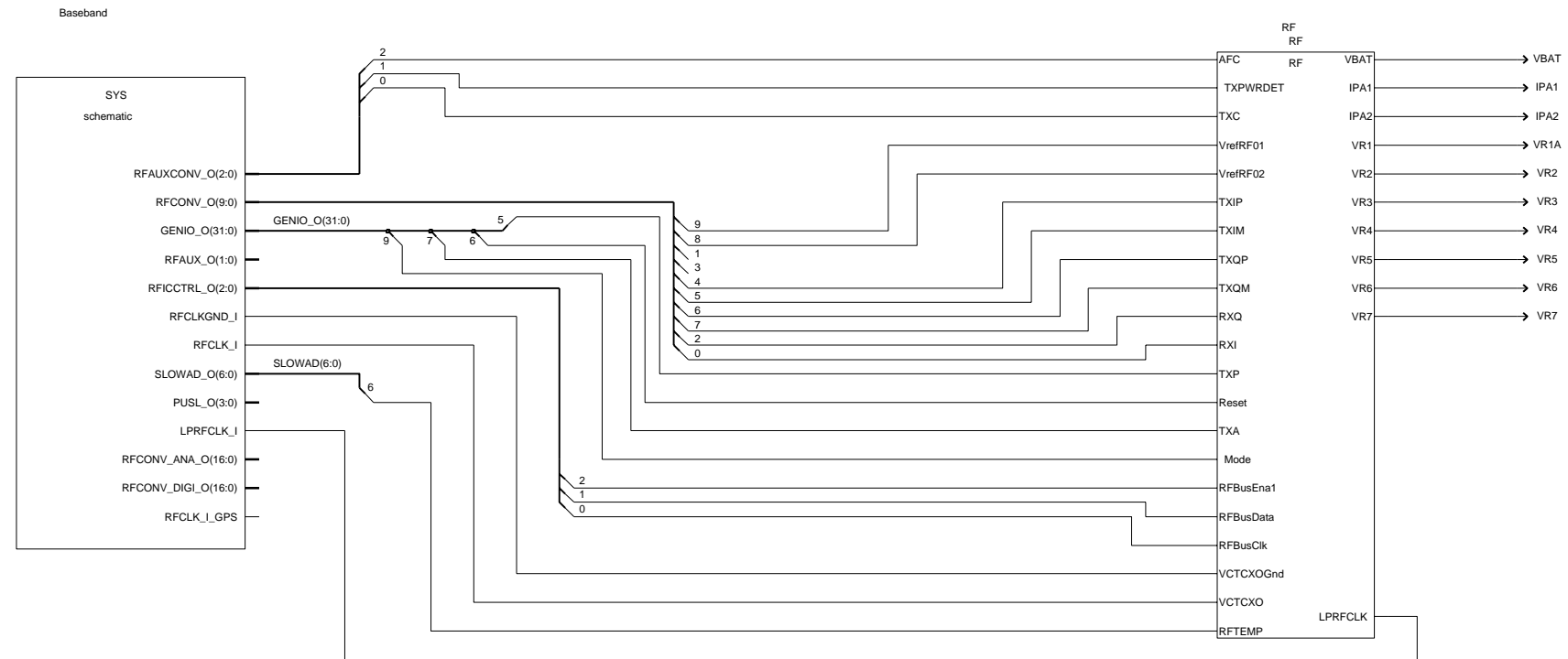

RF Block Diagram v.0.0 ed.13

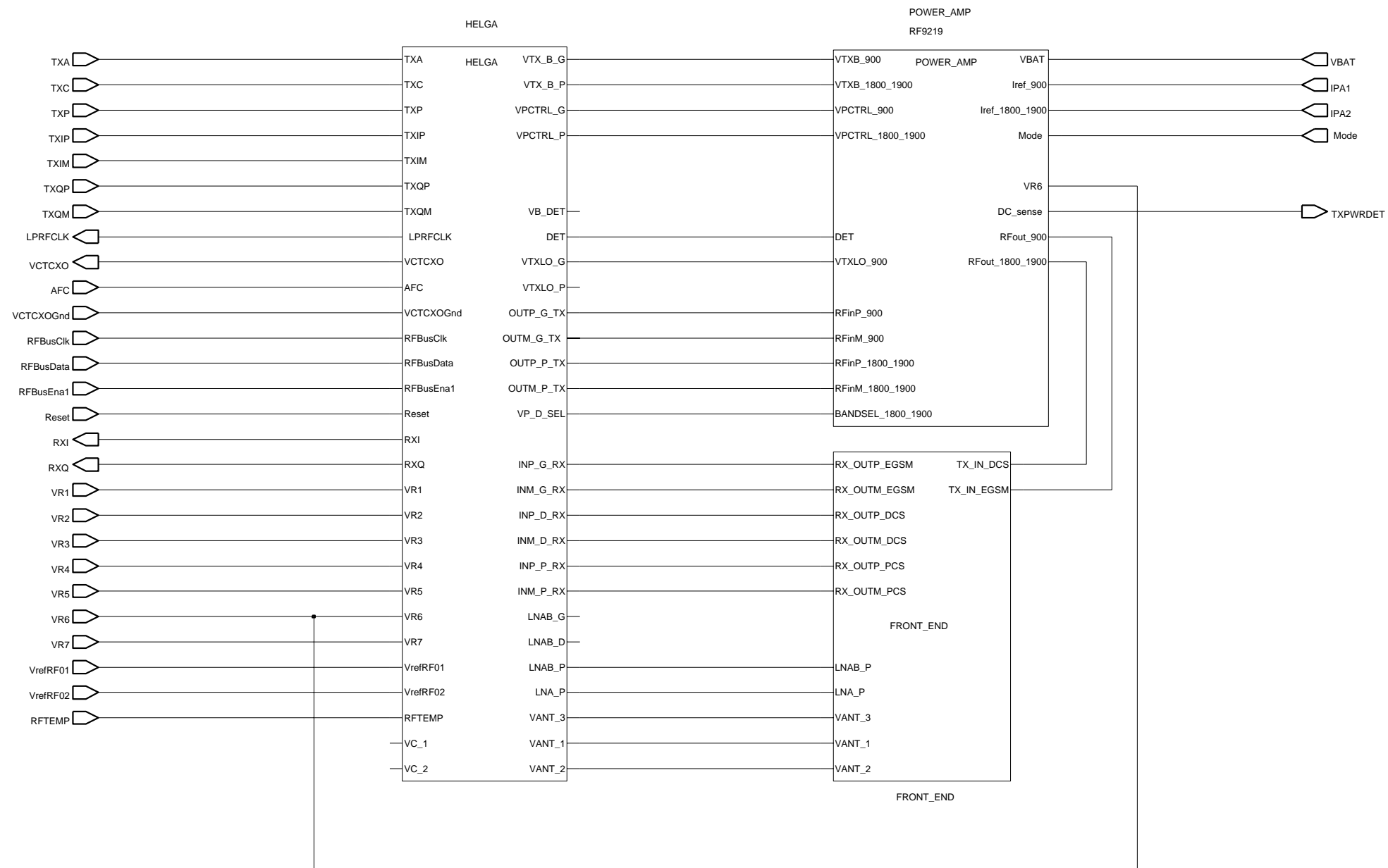

Helga RF Schematic Diagram v. 0.0 ed.42

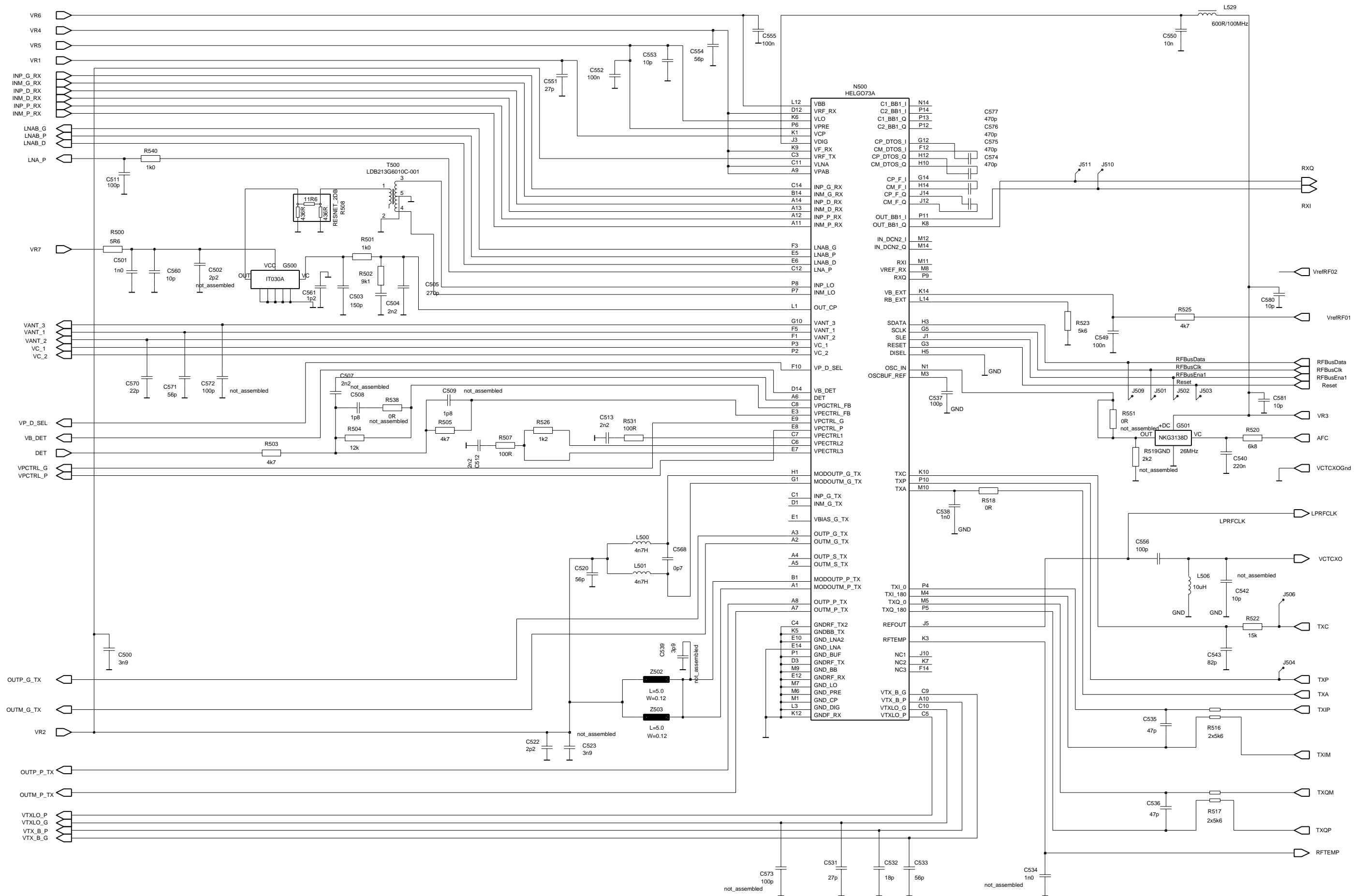

Receiver Front End and Antenna Switch v. 0.0 ed.20

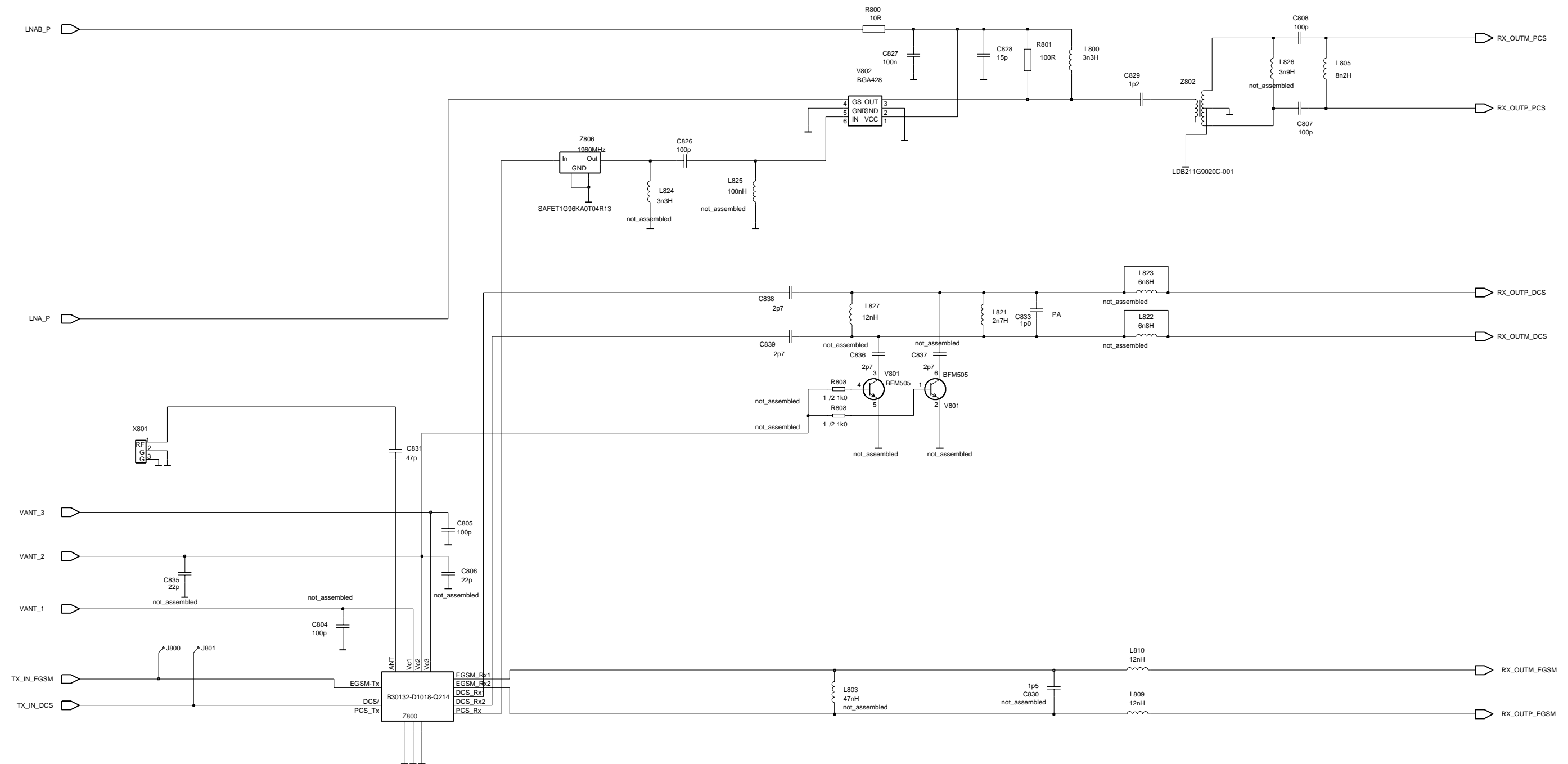

Power Amplifier and Detector v.0.2 ed.26

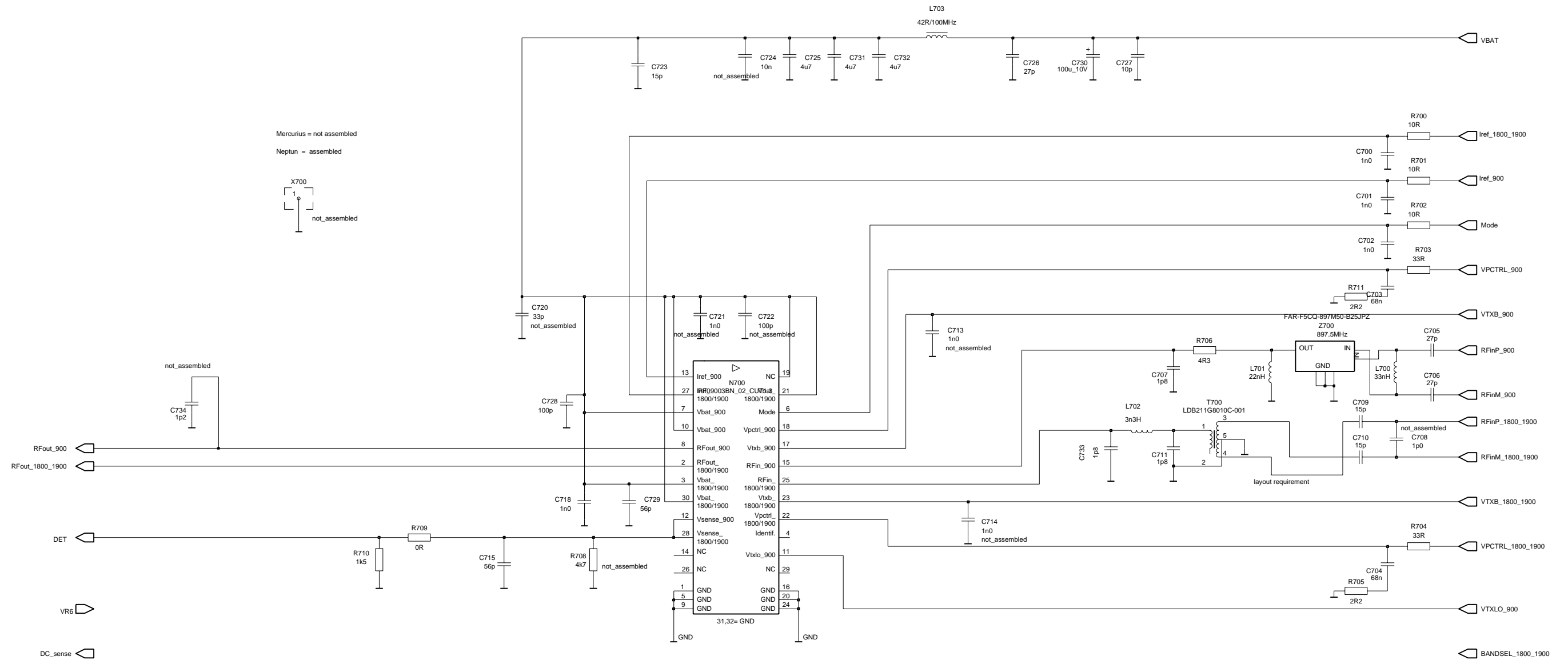

Baseband Block Diagram v. 5.0 ed.33

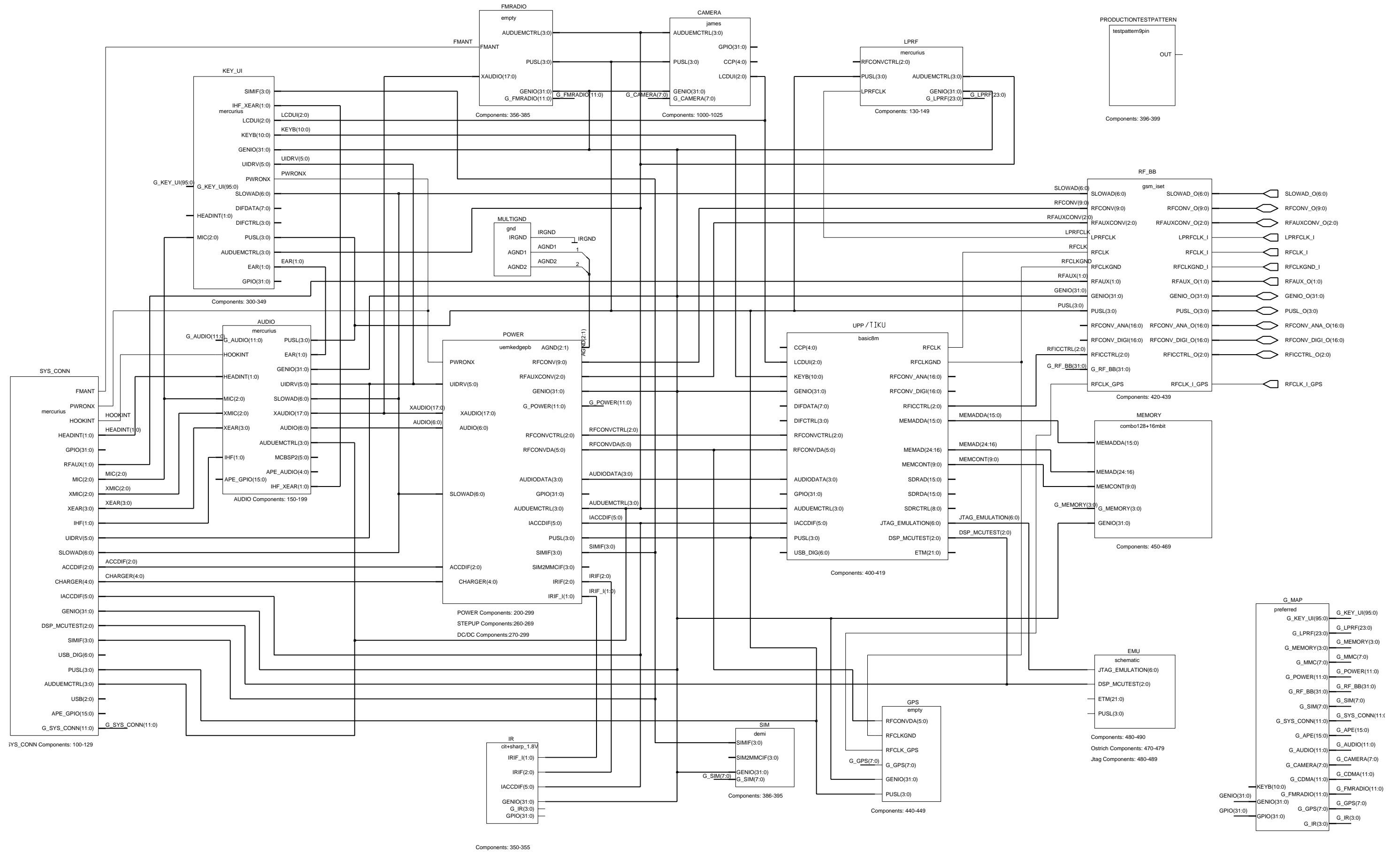

Camera Diagram v. 0.0 ed. 58

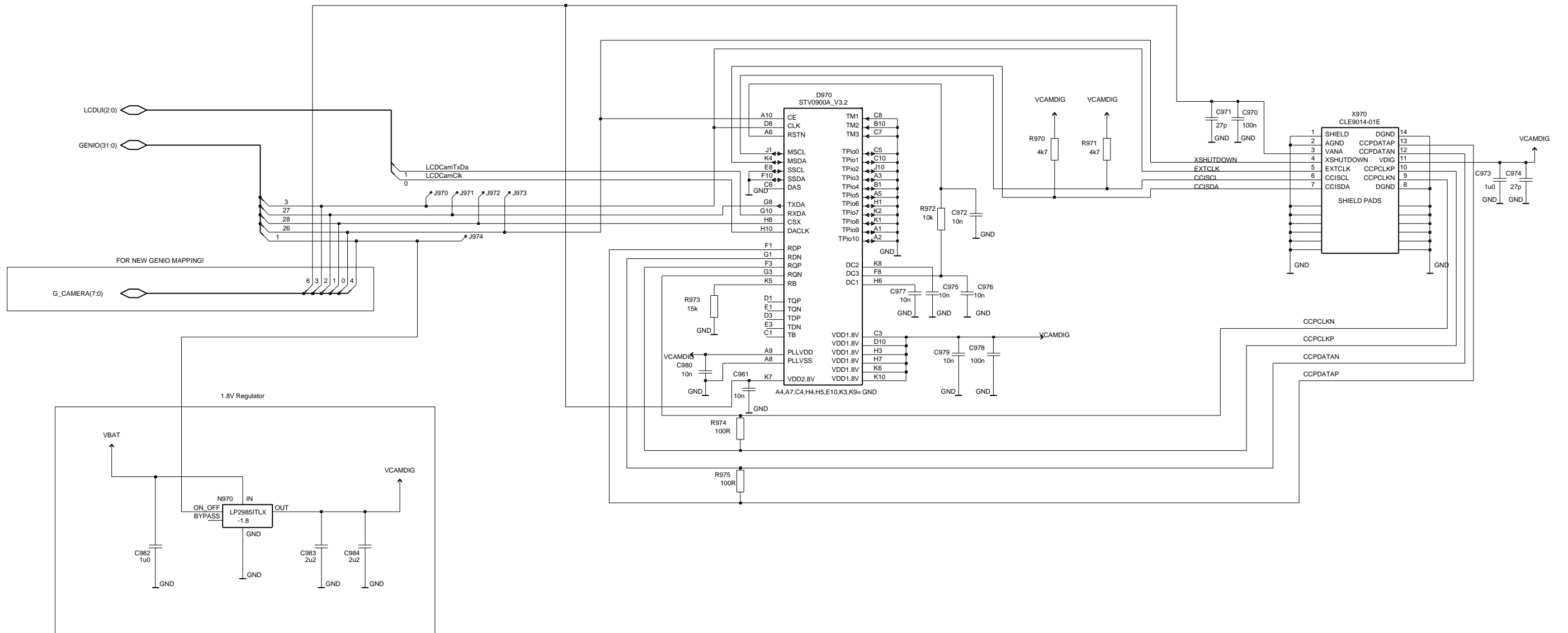
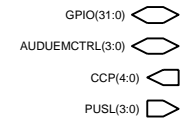

Combo Memory 128+8Mbit v. 2.0 ed.76

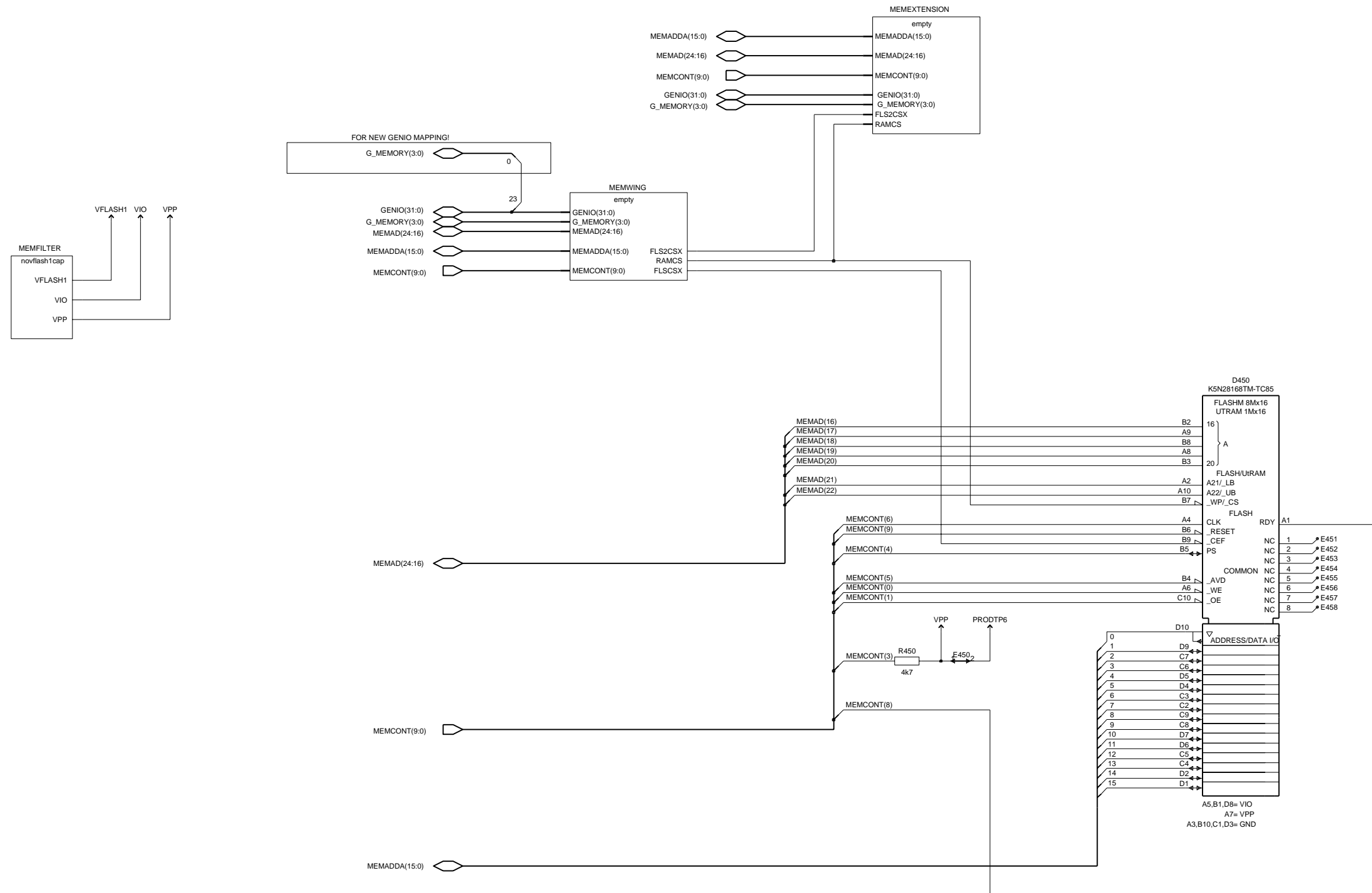

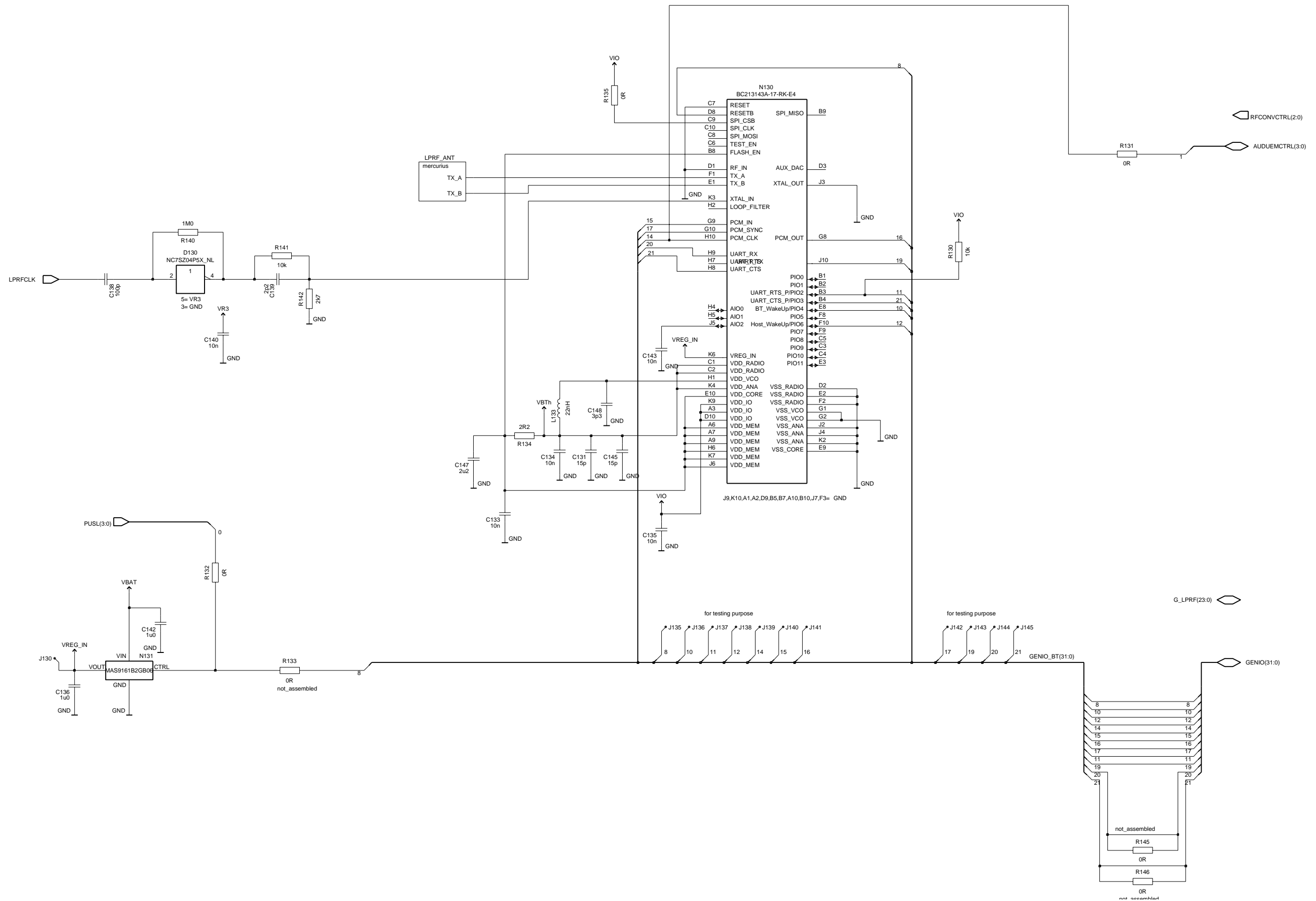

SIM Reader v.1.3 ed.52

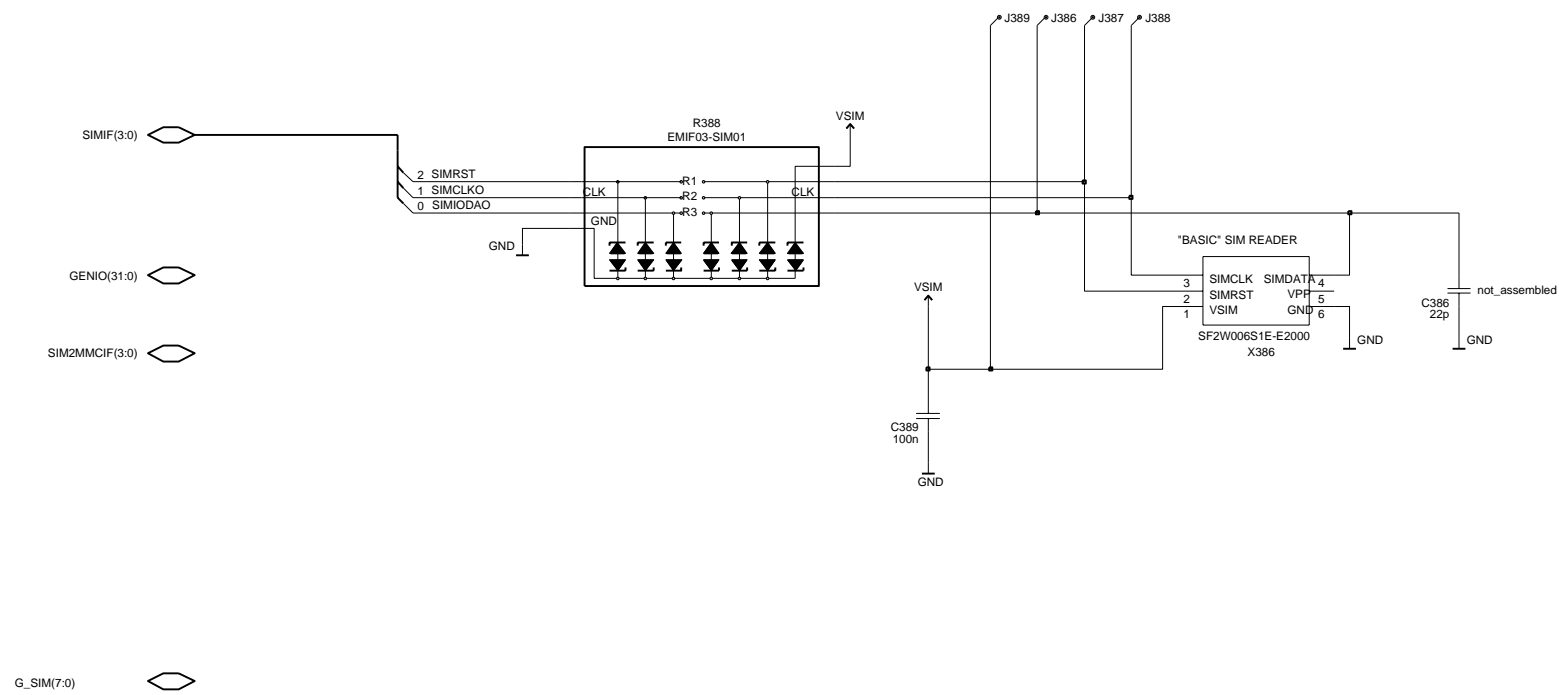

G_SIM(7:0)

Discrete Power Management Diagram v. 1.3 ed.124

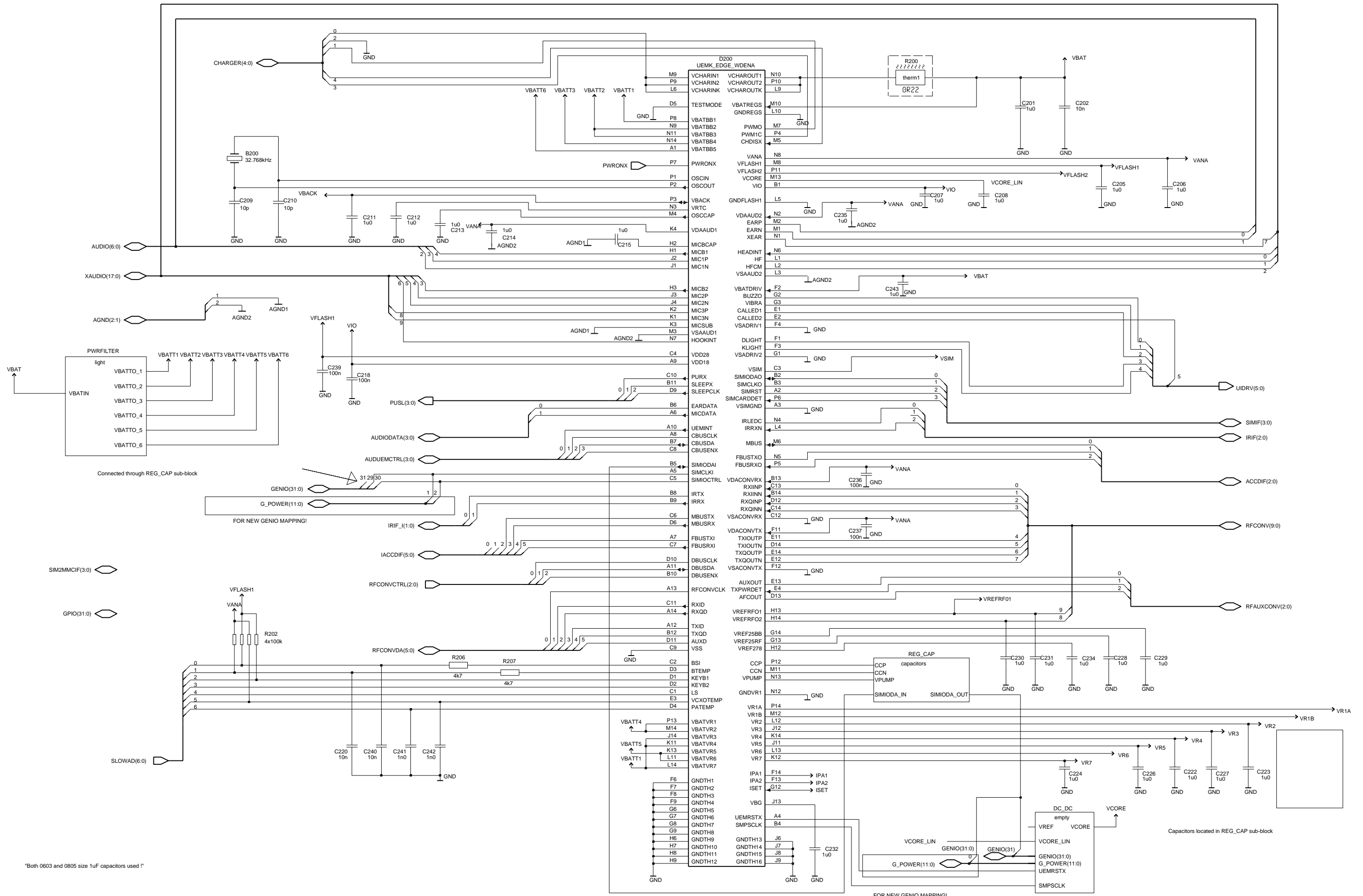

*Both 0603 and 0805 size 1uF capacitors used !

Used refs in REG_CAP: C238, C200, C219, C233, C221 and R205

Back Light Filtering v. 2.0 ed.28

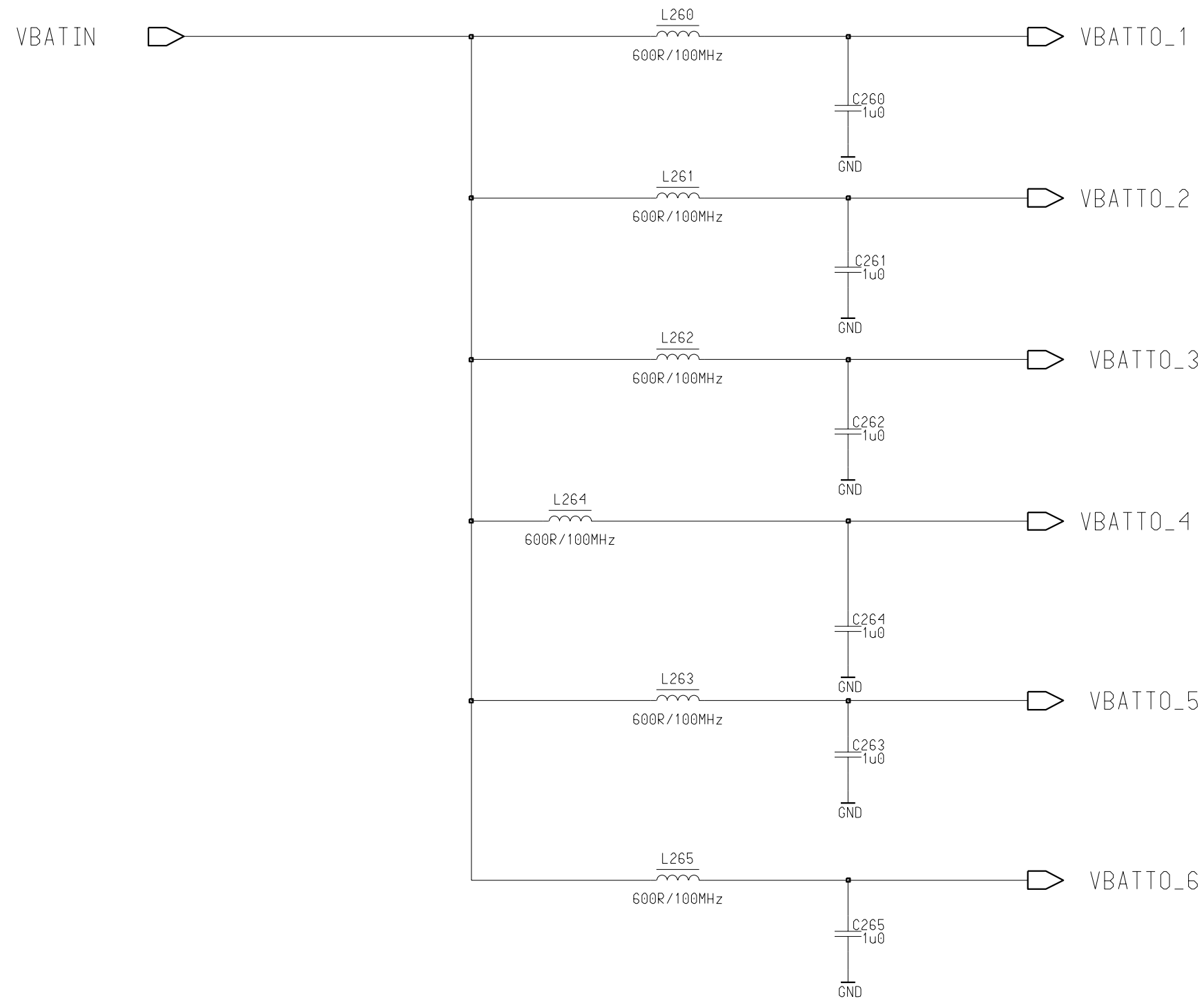

UPP 8M Diagram v. 2.0 ed.104

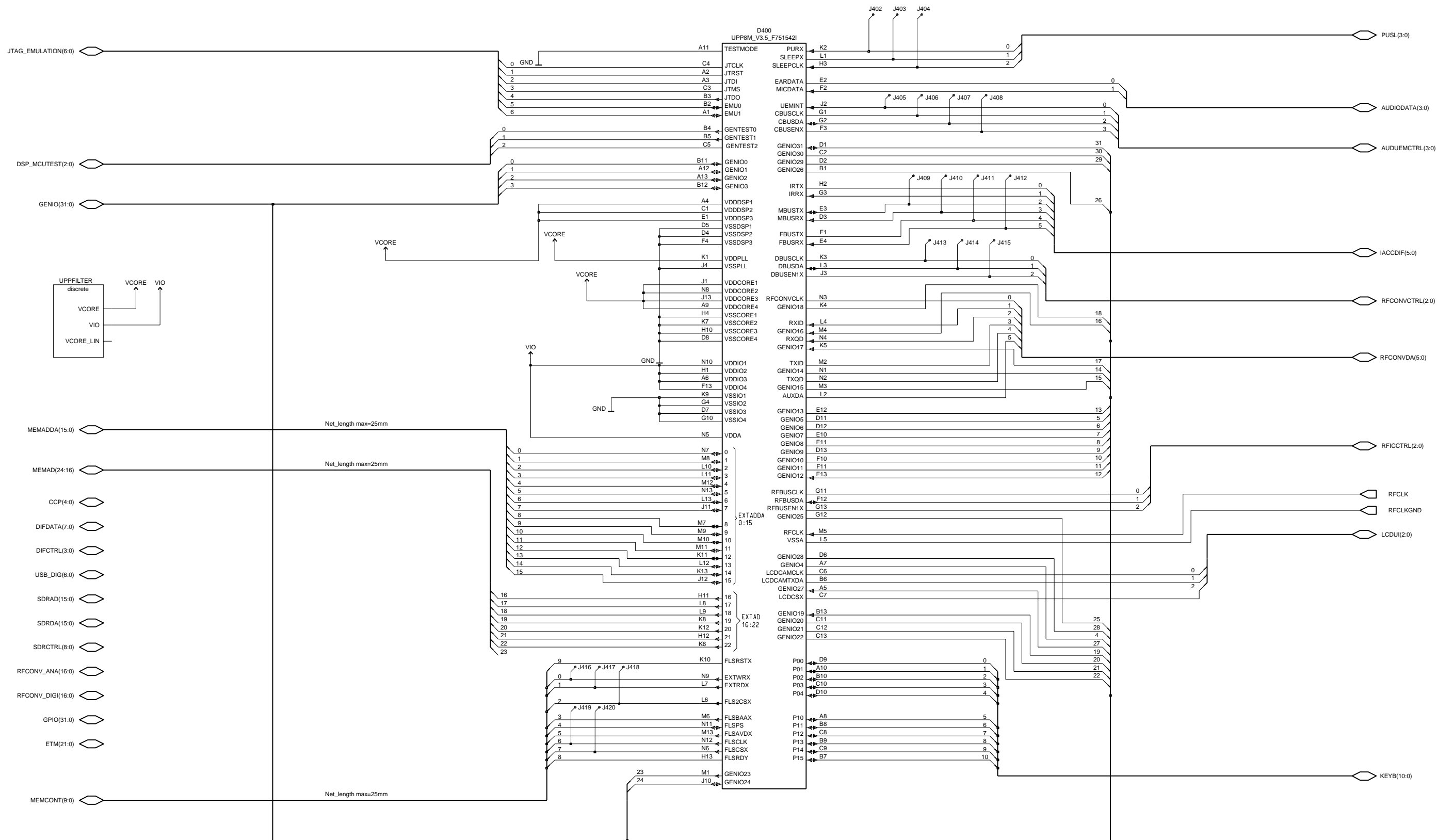

UPP Decoupling Capacitors Diagram v. 1.3 ed. 10

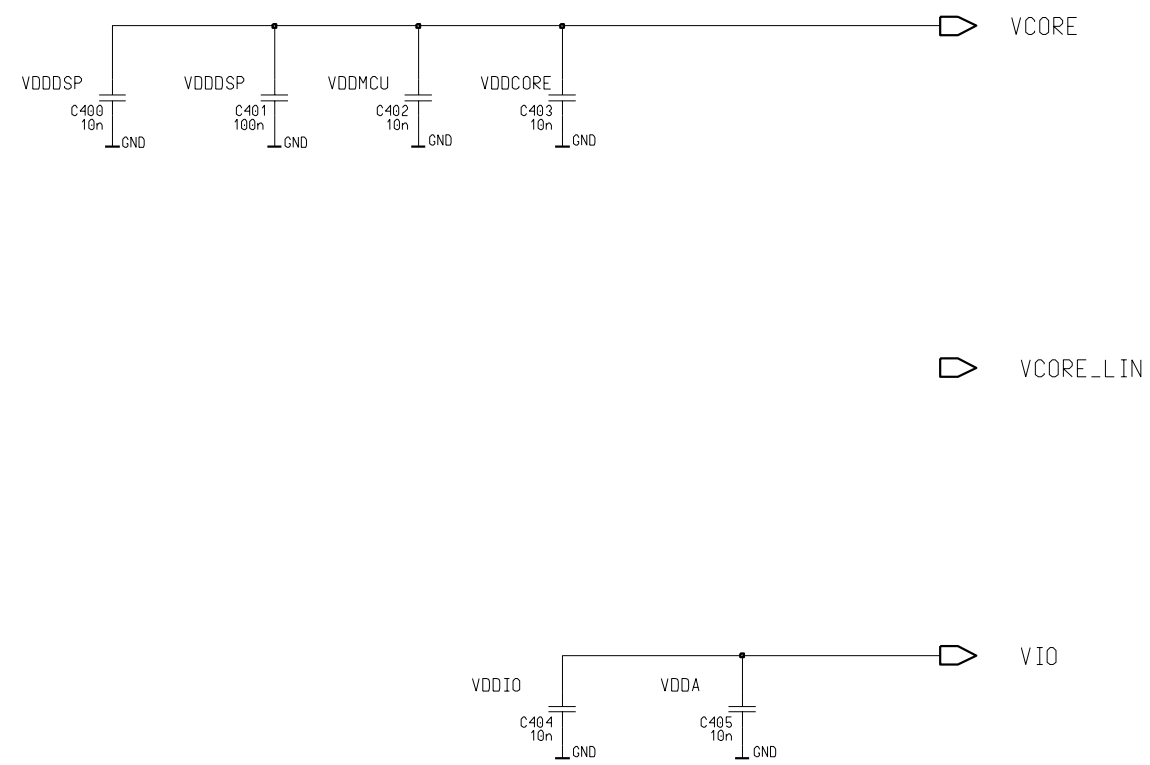

GSM RF-BB Connections v. 1.3 ed.44

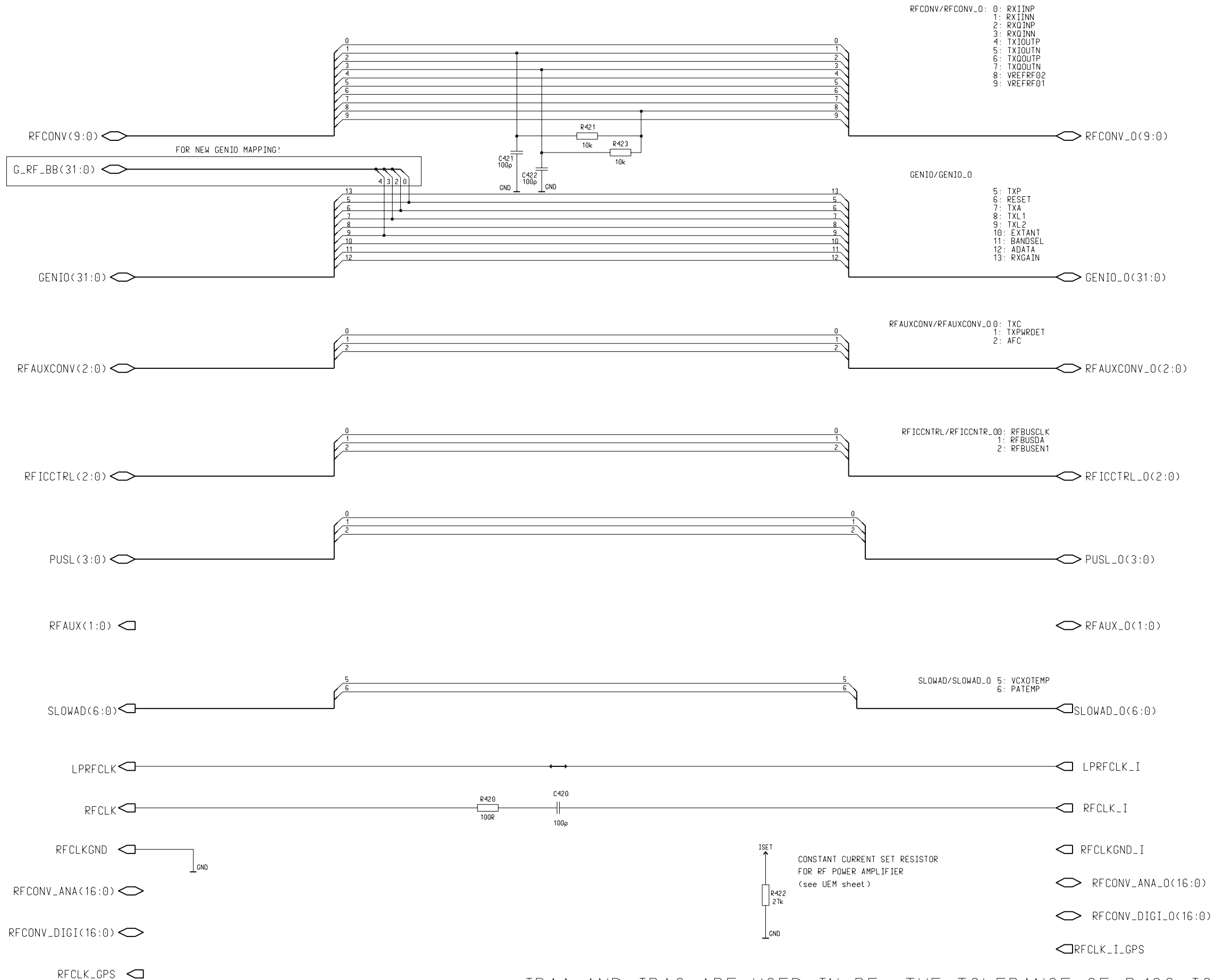

IPA1 AND IPA2 ARE USED IN RF, THE TOLERANCE OF R422 IS 1% (0402, 1430873)

System Connector Diagram v. 0.0 ed. 2

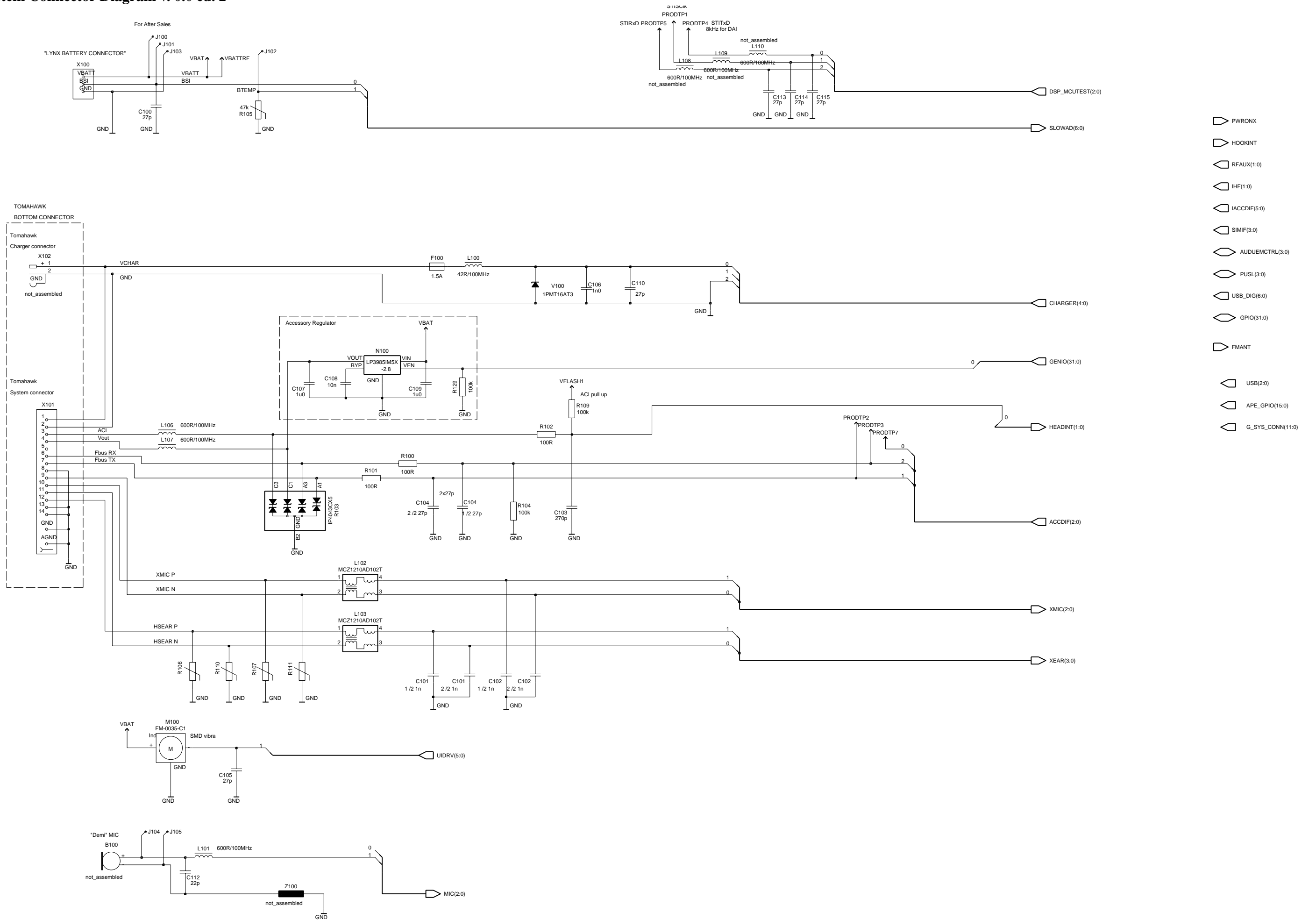

Audio Diagram v.0.0 ed. 51

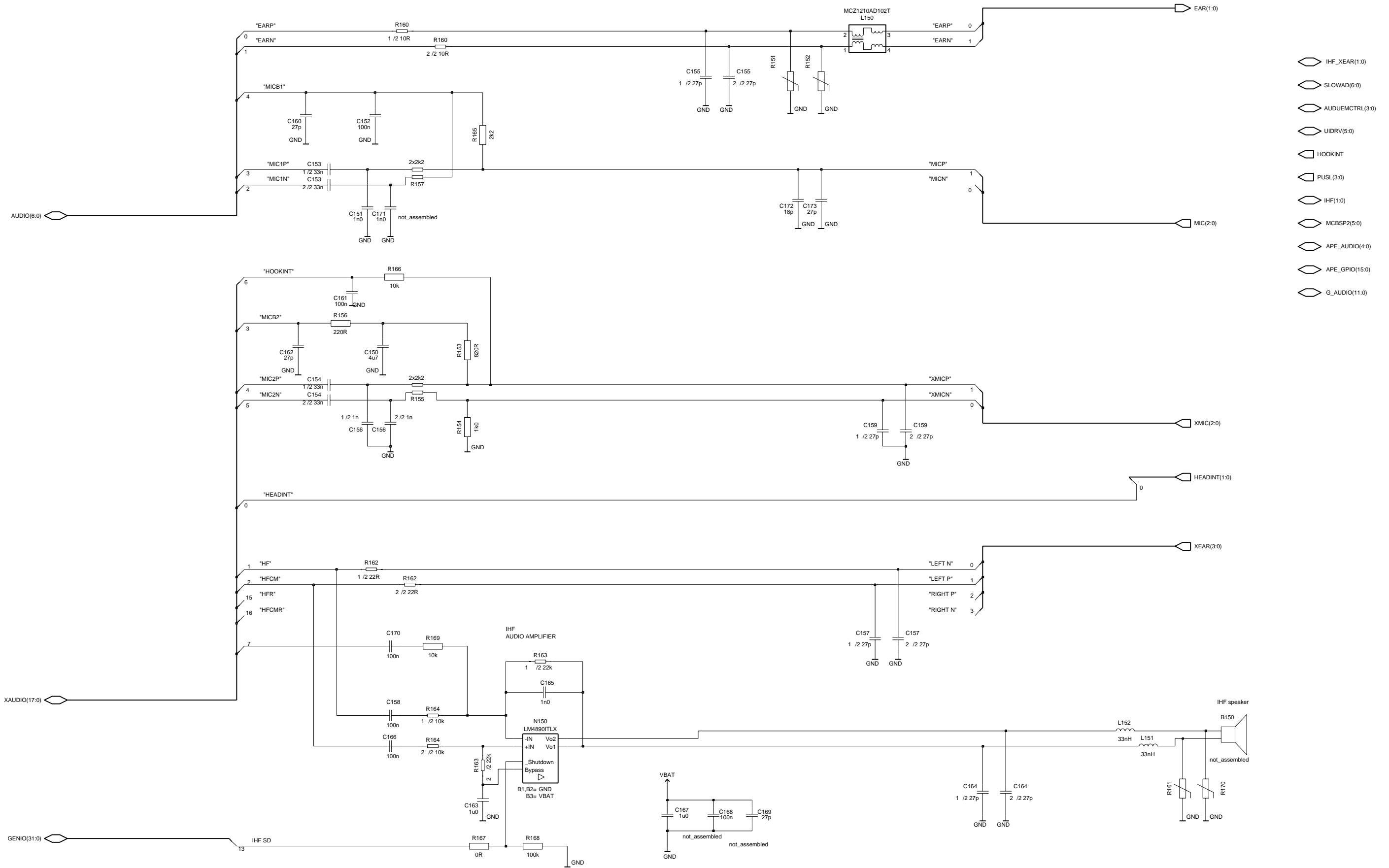

IR Diagram v. 0.0 ed.49

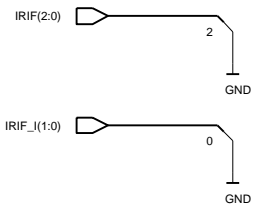
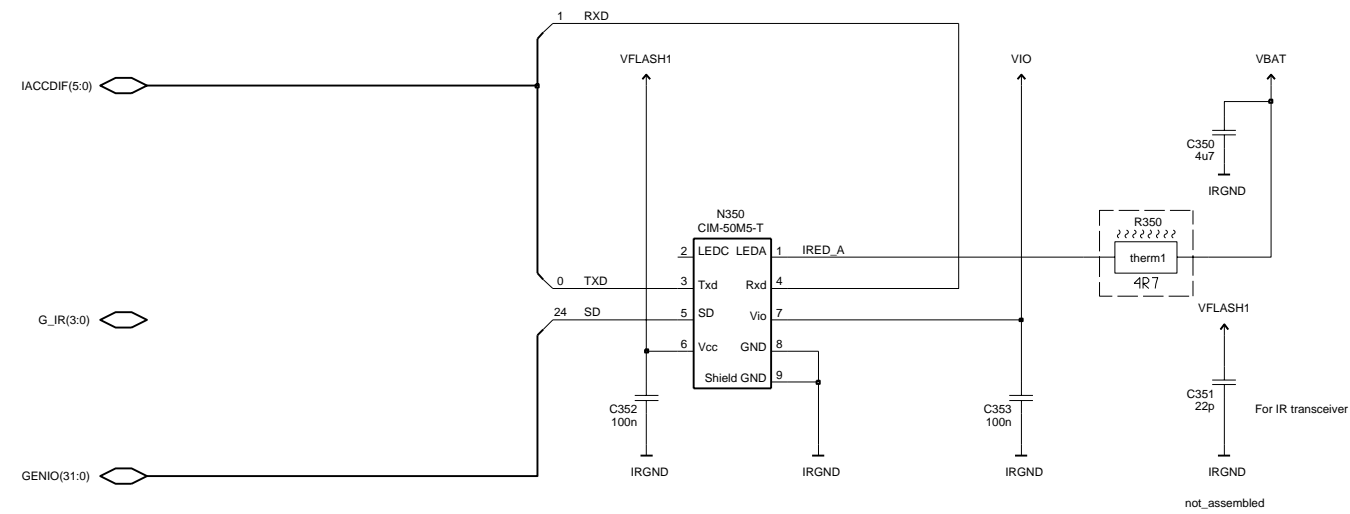

UEM IR level shifters
are ground, when 1.8V
IR is used!

Used referenses

- C 350 - 353
- N 350
- R 350

A
B
C
D

User Interface Diagram v.0.0 ed.119

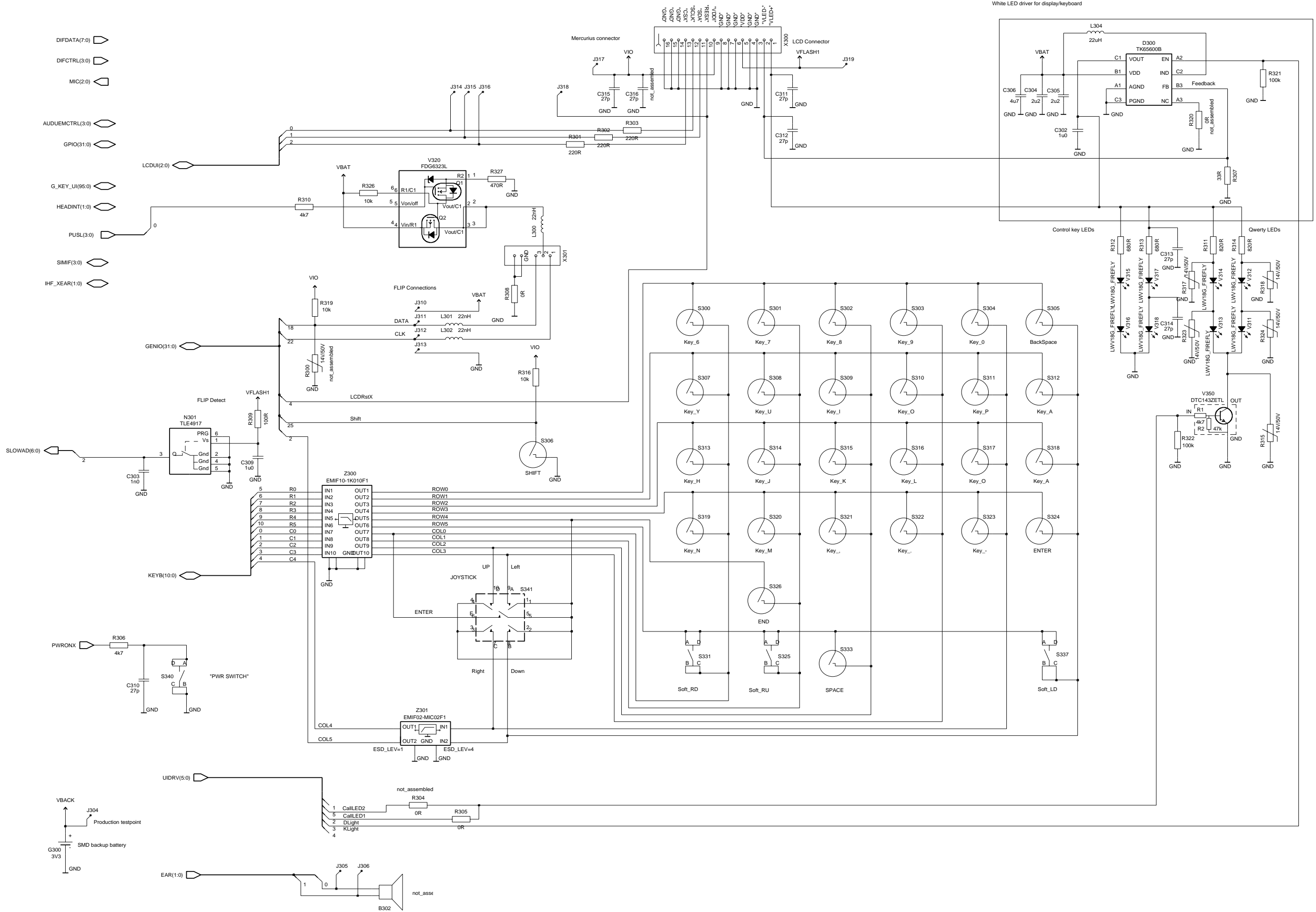

LPRF Antenna Diagram v. 0.0 ed.21

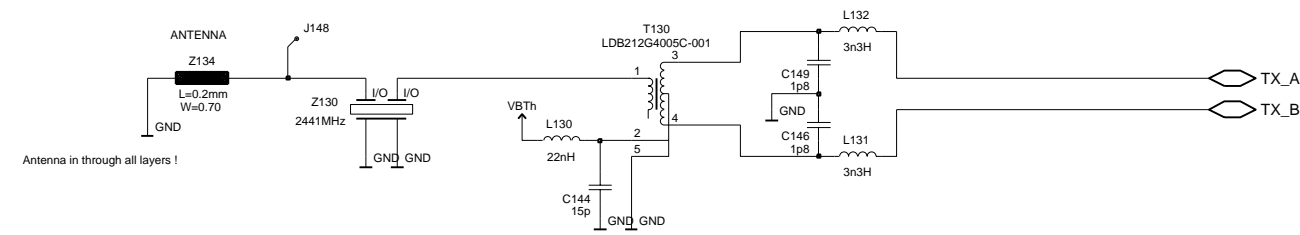

Parts Placement Diagram TB6_17a top

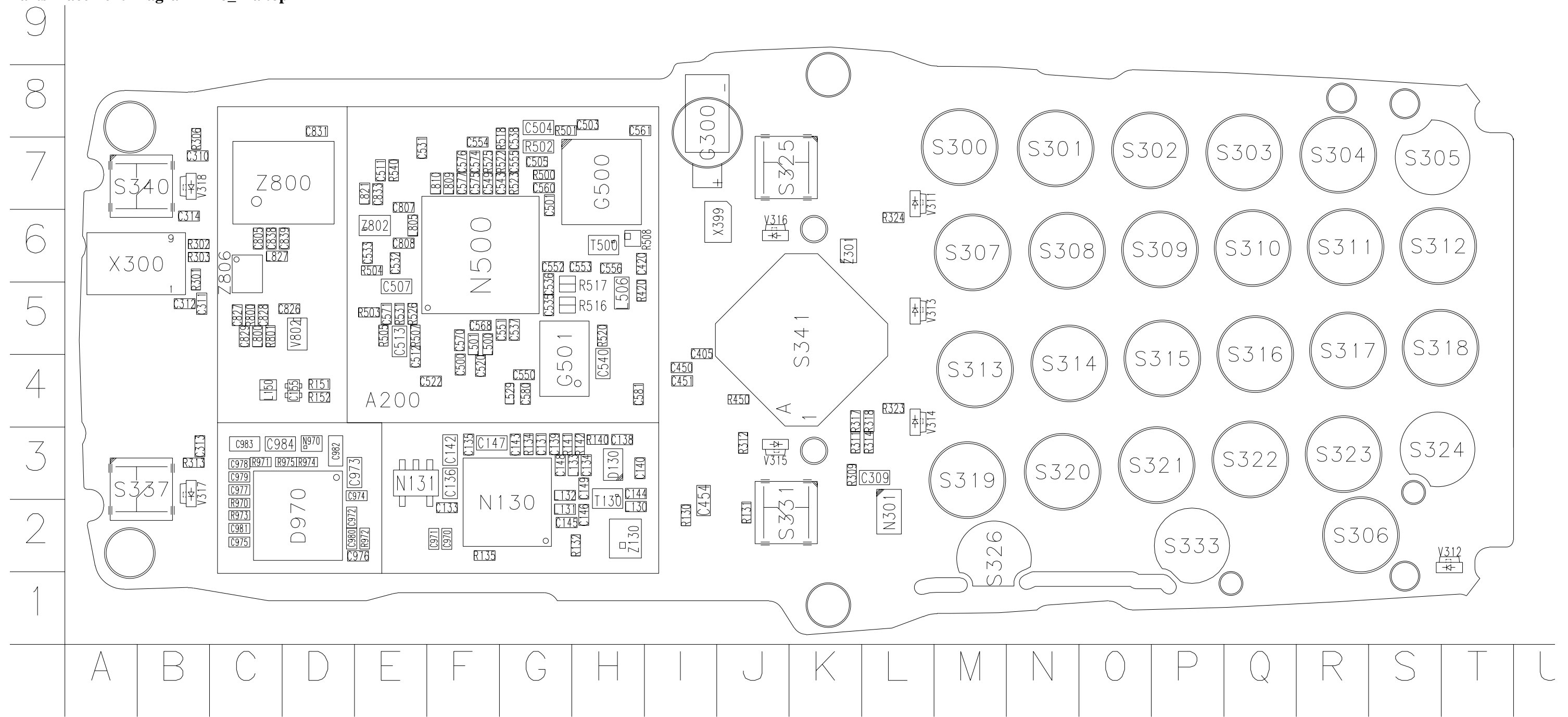

Parts Placement Diagram Bottom

